

Titan Concentric Bracket

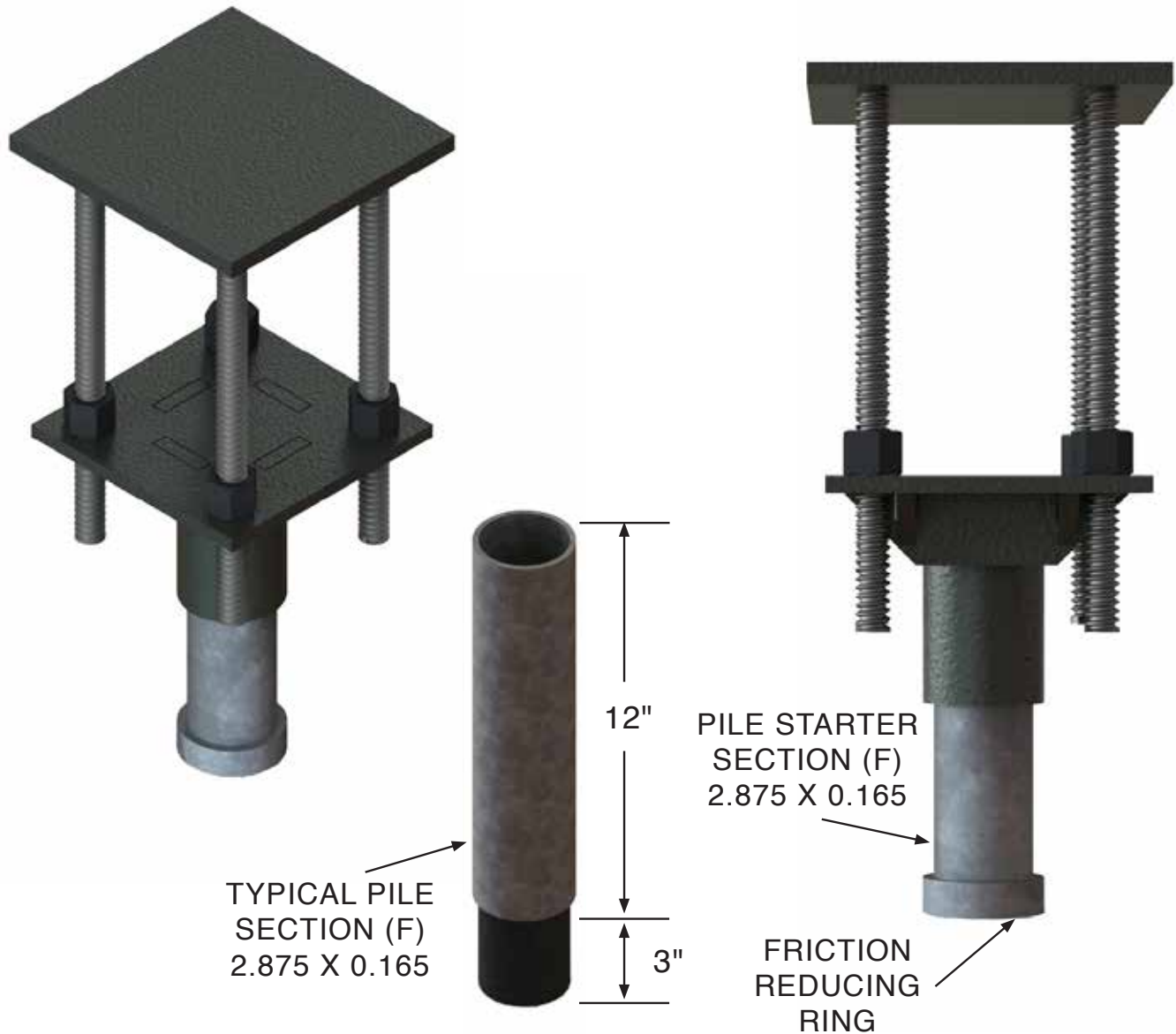

- Ultimate Bearing Capacity = 54,000 lbs
- Bearing Surface Area = 100 in²
- Weight = 30 lbs
- Piles are Field Tested During Installation

- Friction Reducing Ring
- Standard 6" Lift Depending on Cylinder Size & Stroke
- Manufacturer's Limited 25 Year Warranty

The capacity of the Titan Concentric Bracket foundation support system is a function of the capacity of pier pipe and soil surrounding the pipe, capacity of the load bearing stratum, bracket, foundation strength and strength of the bracket to foundation connection. Actual capacities could be lower than the bracket capacity.