

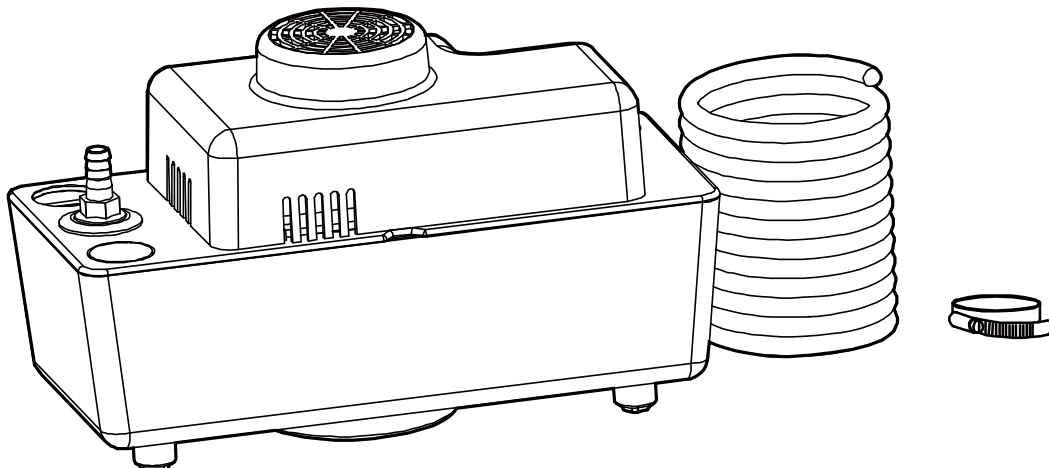

# Westinghouse

# OWNER'S MANUAL

## CONDENSATE PUMP



**Model# WHCP**

## PERFORMANCE

Model	HP	GPH of Water @ Total Feet of Lift				Max. Lift
		0 ft.	5 ft.	10 ft.	15 ft.	
WHCP	1/20	132	108	72	24	18 ft.

## SAFETY INSTRUCTIONS

1. Do not pump flammable or explosive liquids such as oil, gasoline, kerosene, ethanol, etc. Do not use in the presence of flammable or explosive vapors. Using this pump with or near flammable liquids can cause an explosion or fire, resulting in property damage, serious personal injury, and/or death.
2. ALWAYS disconnect the power to the pump before servicing.
3. Release all pressure and drain all water from the system before servicing any component.
4. Secure the discharge line before starting the pump. An unsecured discharge line will whip, possibly causing personal injury, and/or property damage.
5. Extension cords may not deliver sufficient voltage to the pump motor. Extension cords present a life threatening safety hazard if the insulation becomes damaged or the connection ends fall into water. The use of an extension cord to power this pump is not permitted.
6. Wear safety goggles at all times when working with pumps.
7. This unit is designed only for use on 115 volts (single phase), 60 Hz, and is equipped with an approved 3-conductor cord and 3-prong grounded plug. Do not remove the ground pin under any circumstances. The 3-prong plug must be directly inserted into a properly installed and grounded 3-prong, grounding-type receptacle. Do not use this pump with a 2-prong wall outlet. Replace the 2-prong outlet with a properly grounded 3-prong receptacle (a GFCI outlet) installed in accordance with the National Electrical Code and local codes and ordinances. All wiring should be performed by a qualified electrician.
8. Protect the electrical cord from sharp objects, hot surfaces, oil, and chemicals. Avoid kinking the cord. Do not use damaged or worn cords.
9. Failure to comply with the instruction and designed operation of this unit may void the warranty. ATTEMPTING TO USE A DAMAGED PUMP can result in property damage, serious personal injury, and/or death.
10. Ensure that the electrical circuit to the pump is protected by a 10 Amp fuse or circuit breaker.
11. Do not lift the pump by the power cord.
12. Know the pump and its applications, limitations, and potential hazards.
13. Follow all local electrical and safety codes, along with the National Electrical Code (NEC). In addition, all Occupational Safety and Health Administration (OSHA) guidelines must be followed.
14. The motor of this pump has a thermal protector that will trip if the motor becomes too hot. The protector will reset itself once the motor cools down and an acceptable temperature has been reached. The pump may start unexpectedly if it is plugged in.
15. Ensure the electrical power source is adequate for the requirements of the pump.
16. Before using the pump, check the tubing for holes or excess wear, which could cause leaks, and ensure the tubing is not kinked or making sharp angles. Straight tubing allows the pump to move the greatest amount of water quickly, and also check that all tubing connections are tight to minimize leaks.
17. This pump is made of high-strength, corrosion-resistant materials. It will provide trouble-free service for a long time when properly installed, maintained, and used. Please carefully read the manual and follow the instructions regarding common pump problems and remedies.
18. This pump is fully automatic in operation. The float switch controls the pump's "ON" and "OFF".

# PRE-OPERATION

## APPLICATION

- This non-submersible utility pump is designed for condensate removal applications. Pump water only with this pump.
- This pump has not been tested or approved for use in swimming pools or in salt-water marine areas. This pump is not designed to function as a permanently installed sump pump. It is also not engineered to run continuously as a “fountain” or “waterfall” pump.
- Do not use where water recirculates.
- Not designed for the drains of swimming pools.

## Function

Operating water depth: minimum, 2-1/4 in.

## TOOLS REQUIRED

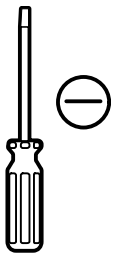

Flathead  
Screwdriver

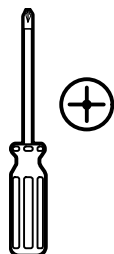

Phillips  
Screwdriver



Safety goggles

## SPECIFICATIONS

Power supply	115V, 60 HZ., 10 Amp Circuit
Liquid temp. range	32 to 95°F (0- 35°C)
Discharge size	3/8 in. hose barb

# OPERATION

## 1. Mounting the pump

- The tank has two slots (1) provided to mount the unit. The slots are located on the back of the tank. Mount the unit either on the side of the air conditioner unit or nearby wall.
- The pump must be level and the inlet must be below the coil drain. Conduit fittings are not compatible with the plastic pump housing.

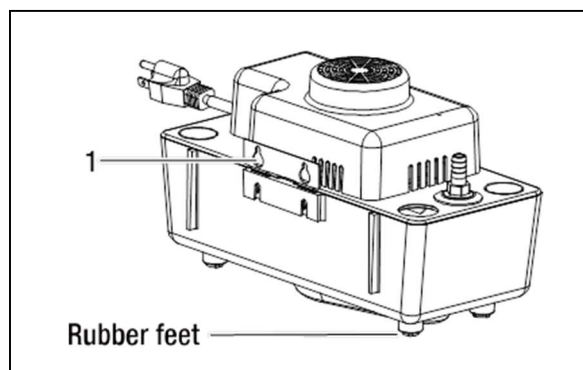

## 2. Connecting the air conditioning condensate drain tubing

- Ensure the tubing to the pump intake is fastened securely so that it cannot come out of the pump intake port.
- Cut the tubing at an angle so that the bottom of the reservoir does not close the tubing outlet. Be sure the tubing does not interfere with the float.

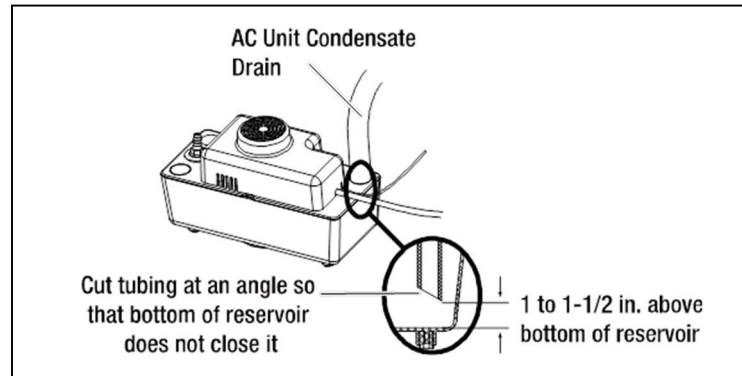

## 3. Connecting the tubing

- Connect the tubing from the pump discharge hose barb to the floor drain, laundry tub, or sink. Leave an air gap above the tub drain.

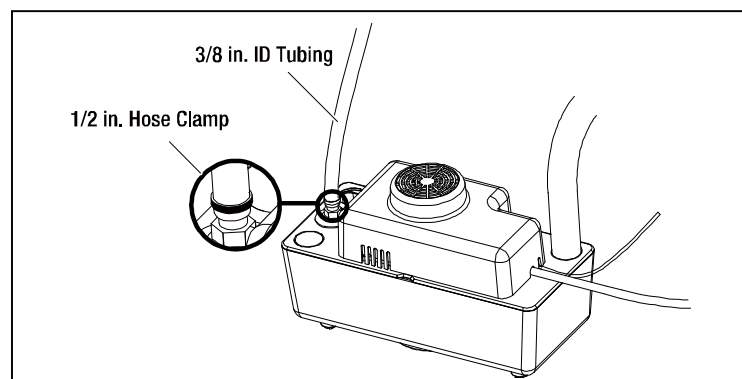

## 4. Plugging in the pump

- Plug the pump power cord into a 115 volt properly grounded power outlet.

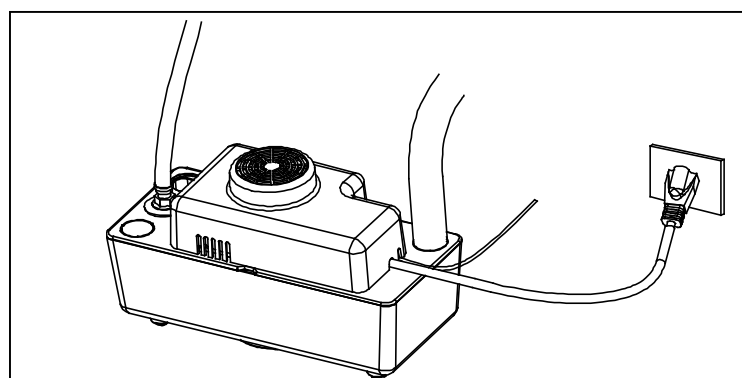

## SAFETY SWITCH

The safety switch is designed to activate an alarm (sold separately) or to cut off power in the event of high water in the condensate reservoir.

To control a thermostatic circuit the COM and NO connections from the safety switch are to be wired in series with the low voltage thermostat circuit to shut down the heating/AC circuit. The COM and NC switch contacts may be used to actuate a low voltage alarm circuit (connected in series) if the heating/cooling system cannot be disrupted.

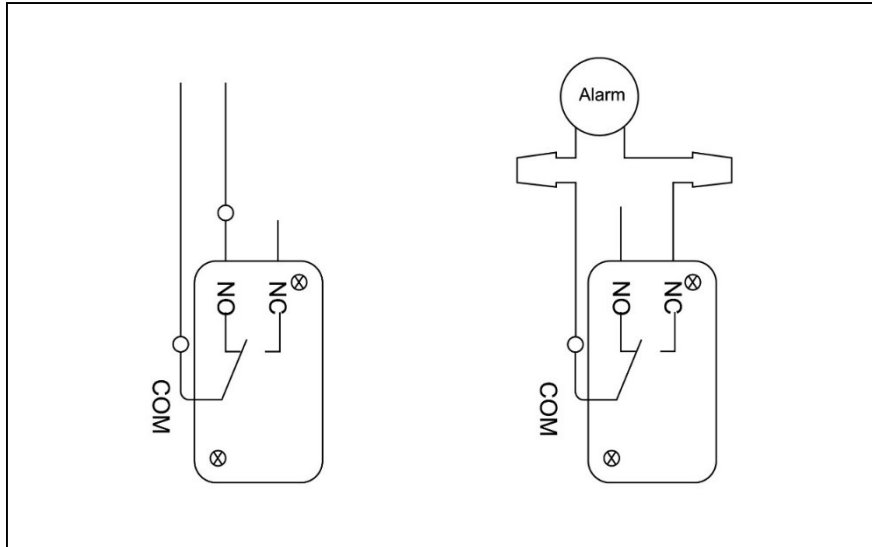

## TESTING

Unplug the condensate pump so that it cannot pump out water. Fill water into the pump reservoir until it is almost full. The safety switch should activate before the float contacts the cover.

1. Plug in the condensate pump. The float should activate the pump and pump the water out.

As the water level goes down in the reservoir, the safety switch should reset, allowing the appliance to start or shut off the alarm.

## TROUBLESHOOTING

Problem	Possible Cause	Corrective Action
The pump does not start.	<ol style="list-style-type: none"> <li>1. The fuse is blown.</li> <li>2. The breaker is tripped.</li> <li>3. The plug is disconnected.</li> <li>4. The plug is corroded.</li> <li>5. The float is stuck.</li> <li>6. The water level is too low.</li> </ol>	<ol style="list-style-type: none"> <li>1. Replace the fuse.</li> <li>2. Reset the breaker.</li> <li>3. Secure the plug.</li> <li>4. Clean the plug prongs.</li> <li>5. Clean the reservoir and ensure the float moves freely.</li> <li>6. Allow the water level to rise to about 2 in. below the top of the pump cover for the pump to start.</li> </ol>
The pump is unable to pump out water.	<ol style="list-style-type: none"> <li>1. The tubing is kinked, bent sharply, or coiled.</li> <li>2. The tubing length is too long.</li> </ol>	<ol style="list-style-type: none"> <li>1. Straighten the tubing.</li> <li>2. Shorten the discharge tubing.</li> </ol>

# WARRANTY

## WESTINGHOUSE RESIDENTIAL PUMPS

### LIMITED PUMP WARRANTY

#### LIMITED WARRANTY

Westinghouse Residential Pumps warrants the products covered by this Limited Warranty to be free from defects in material or workmanship for the periods set forth below.

- CONDENSATE PUMP (WHCP 860010653647) – 1 year from date of purchase

Subject in all respects to the terms and conditions set forth in this Limited Warranty, during the applicable warranty period, Westinghouse Residential Pumps will repair or replace to the original consumer any portion of the subject product which proves defective due to defective materials or workmanship.

The determination of whether to repair or replace defective product or components shall be in the sole and absolute discretion of Westinghouse Residential Pumps. Westinghouse Residential Pumps may elect to inspect any product claimed to be defective under this limited warranty to confirm applicability of this limited warranty.

THIS WARRANTY SETS FORTH WESTINGHOUSE RESIDENTIAL PUMPS SOLE OBLIGATION AND CONSUMER'S EXCLUSIVE REMEDY FOR DEFECTIVE PRODUCT.

#### GENERAL TERMS AND CONDITIONS; WARRANTY EXCLUSIONS

This Limited Warranty shall not apply to damage due to acts of God, normal wear and tear, normal maintenance services and the parts used in connection with such service, damages caused by lightning strikes or other acts of nature, power surges or conditions beyond the control of Westinghouse Residential Pumps. This Limited Warranty shall not apply to products which, in the sole judgment of Westinghouse Residential Pumps, have been subject to negligence, abuse, accident, misuse, tampering, alteration, improper installation, operation, maintenance or storage.

This Limited Warranty will be VOIDED if any of the following conditions are found to have occurred:

- Commercial or industrial use of the product.
- The product is not installed in accordance with applicable codes, ordinances, and good trade practices.
- The product is not operated or maintained in accordance with the printed instructions provided.
- The product is used for purposes other than those for which it was designed and manufactured.
- The product is connected to voltage other than indicated on nameplate or labels.
- The product is exposed to abrasive or corrosive substances including but not limited sand, gravel, cement, grease, plaster, mud, tar, oil, gasoline, solvents.
- The product has been used for pumping liquids below 32°F or above 95°F.
- The product has been allowed to operate dry (liquid supply cut off).

Westinghouse Residential Pumps shall NOT be responsible or liable for the cost of field labor or other charges incurred by customer in removing or reinstalling any product, part, or component.

THIS LIMITED WARRANTY DOES NOT COVER REPLACEMENT PARTS FOR FAILURE DUE TO NORMAL WEAR AND TEAR. THIS LIMITED WARRANTY DOES NOT COVER THE COST OR VALUE OF DAMAGED PROPERTY, INCLUDING ANY PROPERTY AFFECTED BY WATER OVERFLOW, SEEPAGE OR FLOODING.

## LIMITATIONS

Westinghouse Residential Pumps only obligation, and user's only remedy, shall be the replacement and/or repair by Westinghouse Residential Pumps of the product as described above. WESTINGHOUSE RESIDENTIAL PUMPS SHALL NOT BE LIABLE FOR ANY INJURY, LOSS OR DAMAGE, DIRECT, INCIDENTAL OR CONSEQUENTIAL (INCLUDING, BUT NOT LIMITED TO, INCIDENTAL OR CONSEQUENTIAL DAMAGES FOR LOST PROFITS, INJURY TO PERSON OR DAMAGE TO PROPERTY, OR ANY OTHER INCIDENTAL OR CONSEQUENTIAL LOSS), ARISING OUT OF THE USE OR THE INABILITY TO USE THE PRODUCT, AND THE USER AGREES THAT NO OTHER REMEDY SHALL BE AVAILABLE TO IT. Before using, the user shall determine the suitability of the product for user's intended use, and user assumes all risk and liability in connection therewith.

TO THE MAXIMUM EXTENT PERMITTED BY LAW, THE WARRANTY AND REMEDY DESCRIBED IN THIS LIMITED WARRANTY IS AN EXCLUSIVE WARRANTY AND REMEDY AND IS IN LIEU OF ALL OTHER WARRANTIES OR REMEDIES, ORAL, WRITTEN, STATUTORY, EXPRESSED OR IMPLIED, WHICH OTHER WARRANTIES AND REMEDIES ARE HEREBY EXPRESSLY EXCLUDED, INCLUDING BUT NOT LIMITED TO ANY IMPLIED WARRANTY OF MERCHANTABILITY OR FITNESS FOR A PARTICULAR PURPOSE, TO THE EXTENT EITHER APPLIES TO A PRODUCT SHALL BE LIMITED IN DURATION TO THE PERIODS OF THE EXPRESSED WARRANTIES GIVEN ABOVE. Any oral statements about the product made by Westinghouse Residential Pumps, its representatives, or any other parties do not constitute warranties and shall not be relied upon by the user.

NO AGREEMENT VARYING OR EXTENDING THE FOREGOING WARRANTY AND RELATED REMEDIES WILL BE BINDING UPON WESTINGHOUSE RESIDENTIAL PUMPS UNLESS IN WRITING, SIGNED BY A DULY AUTHORIZED OFFICER OF WESTINGHOUSE RESIDENTIAL PUMPS.

**WESTINGHOUSE RESIDENTIAL PUMPS LIABILITIES IN CONNECTION WITH THE ORDER TO WHICH THIS LIMITED WARRANTY RELATES, WHETHER IN CONTRACT, IN TORT, UNDER ANY WARRANTY OR OTHERWISE, SHALL NOT EXCEED THE TOTAL PURCHASE PRICE OF THE PRODUCT.**

Some jurisdictions do not allow limitations on how long an implied warranty may last and so the above limitation may not apply to you. The above limitation or exclusion of incidental or consequential damages may not apply to you if you are in a state that does not allow the limitation or exclusion of incidental or consequential damages.

If any term in this Limited Warranty is held to be illegal or unenforceable, the legality or enforceability of the remaining terms shall not be affected or impaired.

## WARRANTY CLAIM SUBMISSIONS

All claim submissions under this Limited Warranty should be marked "WARRANTY CLAIM SUBMISSION" and must include a description of the defect, digital photos depicting the defect, and copies of documentation evidencing product purchase date (such as a sales receipt or invoice). WARRANTY CLAIMS MUST BE SUBMITTED WITHIN THIRTY (30) DAYS FROM THE PRODUCT'S DEFECTIVE PERFORMANCE. CLAIMS SUBMITTED AFTER SUCH THIRTY (30) DAY PERIOD WILL NOT BE ELIGIBLE FOR WARRANTY SERVICE.

### WARRANTY CLAIMS MUST BE SENT TO:

Westinghouse Residential Pumps  
4400 Easton Commons  
Suite 250  
Columbus, OH 43219  
Phone: (833) 594-0444  
Email: support@respumps.westinghouse.com