

STAINLESS STEEL SUMP PUMP

CONSTRUCTION

- ▶ Corrosion Resistant Stainless Steel Motor Housing and Fasteners For Long Life in Tough Sump Applications
- ▶ Top Suction Design Eliminates Air Lock and Minimizes Clogging from Debris in the Bottom of the Sump Pit
- ▶ Reliable Thermoplastic Impeller for Maximum Water Flow
- ▶ 1-1/2 in. NPT Discharge for Easy Installation and Compliance with Building Codes
- ▶ For Use In 11 in. Diameter or Larger Sump Basins
- ▶ 8 ft. SJTW Power Cord

BENEFITS

- ▶ This pump is easy to install in a 11" basin. Start to finish in about 15 minutes. No weep hole needed.
- ▶ Quality and Reliability. Warrantied.
- ▶ Experience reliable operation that only an Integrated Vertical Float Switch can deliver.





CORROSION RESISTANT CONSTRUCTION WITH TOP SUCTION DESIGN TO MINIMIZE CLOGGING

MODEL: SSF100S, 1 HP

PUMP SNAPSHOT

- ▶ **HP** - SSF100S, 1 HP
- ▶ **Construction** - Stainless Steel And Cast Iron Bottom
- ▶ **Switch Type** - Integrated Vertical Float Switch
- ▶ **Motor** - 120 Volt, PSC Oil-Filled Motor
- ▶ **Impeller** - Centrifugal
- ▶ **Intake** - Top Suction
- ▶ **Discharge** - 1 1/2 In. NPT
- ▶ **Submersible** - Yes
- ▶ **SSF100S UPC** - 040066218988

PUMP SPECIFICATIONS

- ▶ **Length** - 10 1/2 In.
- ▶ **Width** - 9 In.
- ▶ **Height** - 11 In.
- ▶ **Weight** - 23 Lbs.
- ▶ **Power Cord** - 8 Ft.

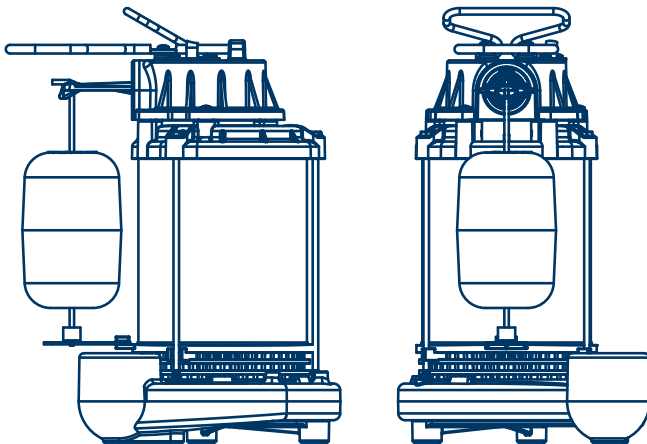

FLOW RATES:

MODEL: SSF100S - 1 HP	GPM @ 5'	GPM @ 10'	GPM @ 15'	GPM @ 20'	
Gal/Min @ 0 MAX Flow	102	94	85	76	64

● SSF100S

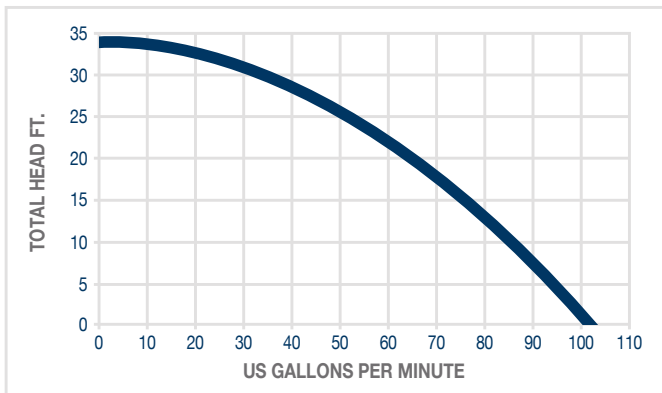

5 YEAR LIMITED WARRANTY

- ▶ Assembled in USA with Foreign and Domestic Parts

